

## 8oz Aqueous Single Wall BioCup ABC-8-UK

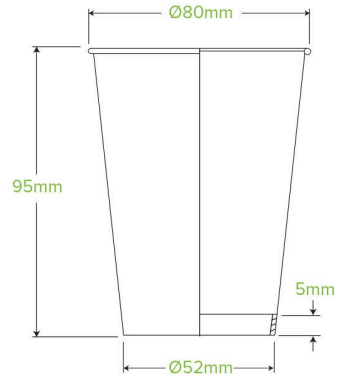

Aqueous Single Wall BioCups are manufactured using a unique water-based dispersion coating certified home compostable to European standards (NF T51-800 ). These cups are food safe, odorless, and can be disposed of right in your backyard compost bin!

<b>Carton quantity:</b> 1000	<b>Sleeves per carton:</b> 20	<b>Units per sleeve:</b> 50
<b>Carton Size LxWxH (cm):</b> 41x33.5x44	<b>Carton gross weight (kg):</b> 9.500000	<b>Raw material:</b> Paper
<b>Lining/coating:</b> Aqueous	<b>Window material:</b> None	<b>Printing Type:</b> Offset
<b>Inks:</b> Food Contact Safe Inks	<b>Brim fill capacity (ml):</b> 280	<b>Dimensions top LxW (mm):</b> 80x80
<b>Dimensions base LxW (mm):</b> 52x52	<b>Product Depth:</b> 95	<b>Product weight (g):</b> 8.3
<b>Thickness:</b> 268gsm + 35gsm	<b>Use:</b> Hot and cold	<b>Manufactured:</b> Taiwan
<b>Customise:</b> Print	<b>MOQ custom:</b> 50000	<b>Mould fees:</b> No
<b>Quality product certified:</b> ISO 9001	<b>Factory food safety certified:</b> BRC, HACCP	<b>Home compostable:</b> Certified to NF T51-800 European standards
<b>Industrially compostable:</b> Certified to AS4736 Australian Standards, Certified to EN13432 European Standard	<b>Recyclable:</b> No	