

750ml Natural BioCane Octa Takeaway Base & Lids - Retail Pack

RT-B-SLB-OCTA-750-N+LID-8X25-UK

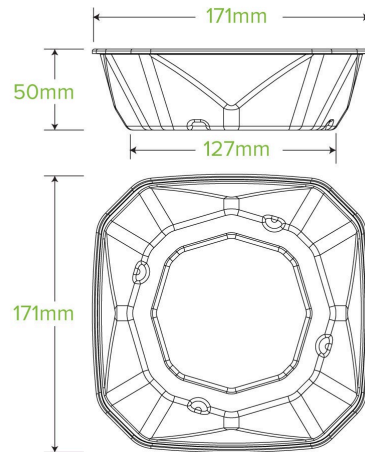

These cartons contain 200 x 750ml Natural Octa Takeaway Containers & 200 x PET Lids to match. The bases are made from reclaimed and rapidly renewable sugarcane pulp, a by-product made of the sugar refining industry. The lids are made from recyclable PET. These containers have a unique octagonal shape for a premium look and feel. PLEASE NOTE THE BELOW SPECIFICATION ONLY APPLIES TO THE BIOCANE BASE.

Carton quantity: 200	Sleeves per carton: 8	Units per sleeve: 25
Carton Size LxWxH (cm): 44.5x39.3x38.7	Carton gross weight (kg): 8.650000	Carton barcode: 5060080976522
Raw material: Bagasse - (100% Sugarcane Pulp)	Printing Type: None	Brim fill capacity (ml): 890
Dimensions top LxW (mm): 171 x 171	Dimensions base LxW (mm): 127 x 127	Product Depth: 50
Use: Hot, Cold, Wet & Dry Products	Manufactured: China	Customise: None
MOQ custom: N/A	Environmental production certified: ISO 14001	Quality product certified: ISO 9001
Factory food safety certified: BRC, HACCP	Home compostable: No	Industrially compostable: No
Recyclable: No		