

630ml Natural BioCane Takeaway Containers B-SLB-630-N-UK

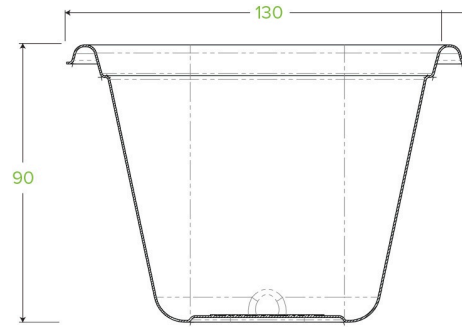

Our plastic-free sugarcane takeaway containers are made from rapidly renewable sugarcane pulp, a by-product of the sugar refining industry. They are microwave and oven friendly.

Carton quantity: 600	Sleeves per carton: 12	Units per sleeve: 50
Carton Size LxWxH (cm): 54.7x30.3x42.8	Carton gross weight (kg): 10.600000	Carton barcode: 19344062009174
Raw material: Bagasse - (100% Sugarcane Pulp)	Printing Type: None	Brim fill capacity (ml): 694
Dimensions top LxW (mm): 130x130	Dimensions base LxW (mm): 65x65	Product Depth: 90
Product weight (g): 14	Thickness: 0.6mm	Use: Hot and cold
Manufactured: China	Customise: Yes - Please Contact Our Team For More Information	MOQ custom: 100000
Mould fees: No	Environmental production certified: ISO 14001	Quality product certified: ISO 9001
Factory food safety certified: BRC, HACCP	Corporate social accreditation: SA 8000	Home compostable: No
Industrially compostable: No	Recyclable: No	