

## 500ml Natural BioCane Containers B-LB-500-N-UK

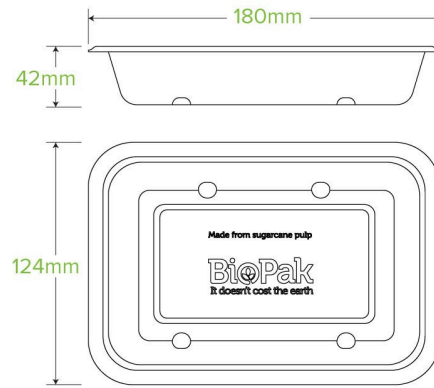

Our plastic-free sugarcane takeaway containers are made from rapidly renewable sugarcane pulp, a by-product of the sugar refining industry. These 500ml natural bagasse disposable container bases are microwave and oven safe.

<b>Carton quantity:</b> 500	<b>Sleeves per carton:</b> 4	<b>Units per sleeve:</b> 125
<b>Carton Size LxWxH (cm):</b> 49.6x38.3x27.3	<b>Carton gross weight (kg):</b> 9.050000	<b>Carton barcode:</b> 19344062033957
<b>Raw material:</b> Bagasse - (70% Sugarcane Pulp & 30% Bamboo Pulp)	<b>Printing Type:</b> None	<b>Brim fill capacity (ml):</b> 617
<b>Dimensions top LxW (mm):</b> 180x124	<b>Dimensions base LxW (mm):</b> 142x87	<b>Product Depth:</b> 42
<b>Product weight (g):</b> 14	<b>Thickness:</b> 0.6mm	<b>Use:</b> Hot, Cold, Wet & Dry Products
<b>Manufactured:</b> China	<b>Customise:</b> Yes - Please Contact Our Team For More Information	<b>MOQ custom:</b> 100000
<b>Mould fees:</b> No	<b>Environmental production certified:</b> ISO 14001	<b>Quality product certified:</b> ISO 9001
<b>Factory food safety certified:</b> BRC, HACCP	<b>Corporate social accreditation:</b> SA 8000	<b>Home compostable:</b> No
<b>Industrially compostable:</b> No	<b>Recyclable:</b> No	