

200ml Clear PLA BioCups R-200Y-UK

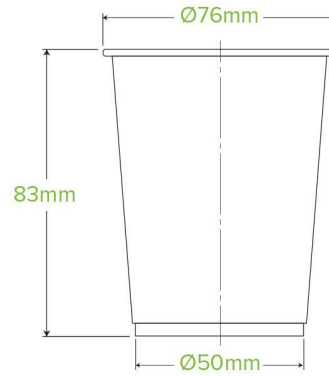

200ml BioCups look and perform like conventional plastic cups but are made from Ingeo™ bioplastic. Certified industrially compostable. Note: cold use only.

Carton quantity: 2000	Sleeves per carton: 20	Units per sleeve: 100
Carton Size LxWxH (cm): 61x40.1x33.2	Carton gross weight (kg): 10.200000	Carton barcode: 19344062000621
Raw material: Bioplastic - PLA	Lining/coating: Bioplastic	Window material: TBC
Printing Type: Offset	Brim fill capacity (ml): 228	Dimensions top LxW (mm): 76x76
Dimensions base LxW (mm): 50x50	Product Depth: 83	Product weight (g): 4.7
Thickness: N/A	Use: Cold, Wet & Dry Products	Manufactured: Taiwan
Customise: Yes - Please Contact Our Team For More Information	MOQ custom: 50000	Mould fees: No
Environmental production certified: ISO 14001	Quality product certified: ISO 9001	Factory food safety certified: HACCP
Corporate social accreditation: SA 8000	Home compostable: No	Industrially compostable: Certified to AS4736 Australian Standards, Certified to EN13432 European Standard
Recyclable: No		