

Natural BioCane Lids to Fit 500/600ml BioCane Containers

B-LBL-N-SMALL-UK

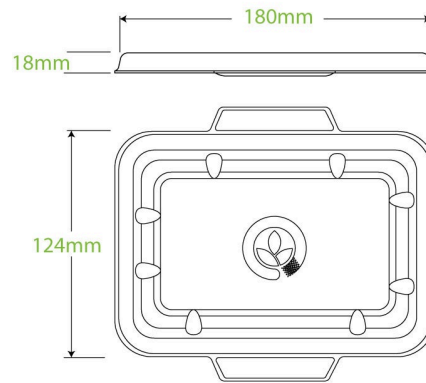

* All items sold separately



Our plastic-free sugarcane takeaway containers are made from rapidly renewable sugarcane pulp, a by-product of the sugar refining industry. They are microwave and oven safe. These 500ml & 600ml natural bagasse food container lids are a great plastic-free option.

Carton quantity: 500	Sleeves per carton: 4	Units per sleeve: 125
Carton Size LxWxH (cm): 51x34.5x39.1	Carton gross weight (kg): 7.400000	Carton barcode: 19344062033971
Raw material: Bagasse - (70% Sugarcane Pulp & 30% Bamboo Pulp)	Printing Type: None	Dimensions top LxW (mm): 180x124
Product Depth: 18	Product weight (g): 12.5	Thickness: 0.6mm
Use: Hot, Cold, Wet & Dry Products	Customise: Yes - Please Contact Our Team For More Information	MOQ custom: 100000
Environmental production certified: ISO 14001	Quality product certified: ISO 9001	Factory food safety certified: BRC, HACCP
Home compostable: No	Industrially compostable: No	Recyclable: No