

## 500-1,000ml CPLA BioBoard Takeaway Lid BB-LBL-CPLA

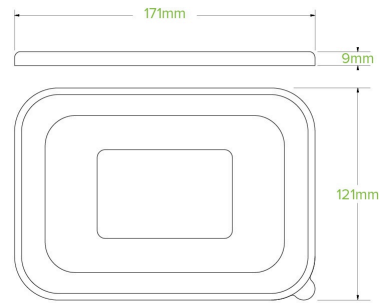

CPLA Rectangle Container Lids are made with plants, not oil, and are suitable for hot food. Matches our 500-1,000ml rectangular paper containers. Certified industrially compostable.

<b>Carton quantity:</b> 300	<b>Sleeves per carton:</b> 6	<b>Units per sleeve:</b> 50
<b>Carton Size LxWxH (cm):</b> 54x34x27	<b>Carton gross weight (kg):</b> 4.150000	<b>Carton barcode:</b> 19344062067945
<b>Raw material:</b> Bioplastic - Ingeo™ PLA	<b>Lining/coating:</b> None	<b>Window material:</b> None
<b>Printing Type:</b> None	<b>Inks:</b> None	<b>Dimensions top LxW (mm):</b> 173x121
<b>Dimensions base LxW (mm):</b> 173x121	<b>Product Depth:</b> 10	<b>Product weight (g):</b> 11
<b>Thickness:</b> N/A	<b>Use:</b> Hot and cold	<b>Manufactured:</b> China
<b>Customise:</b> Emboss	<b>MOQ custom:</b> 50000	<b>Mould fees:</b> Yes - see custom packaging
<b>Environmental production certified:</b> ISO 14001	<b>Quality product certified:</b> ISO 9001	<b>Factory food safety certified:</b> BRC
<b>Corporate social accreditation:</b> BSCI	<b>Home compostable:</b> No	<b>Industrially compostable:</b> Certified to AS4736 Australian Standards
<b>Recyclable:</b> No		