

460ml / 16oz (90mm) Stone Double Wall Biocup ABC-16DW

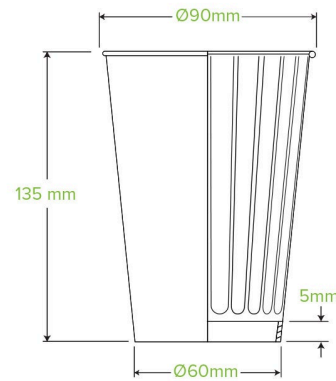

16oz Aqueous Double Wall BioCups are manufactured using a unique water-based dispersion coating certified home compostable to Australian standards (AS5810). These cups are food safe, odorless, and can be disposed of right in your backyard compost bin!

Carton quantity: 600	Sleeves per carton: 15	Units per sleeve: 40
Carton Size LxWxH (cm): 46.5x28.5x63	Carton gross weight (kg): 13.000000	Carton barcode: 19344062063893
Raw material: Paper	Lining/coating: Aqueous	Window material: None
Printing Type: Offset	Inks: Food Contact Safe Inks	Brim fill capacity (ml): 395
Dimensions top LxW (mm): 90x90	Dimensions base LxW (mm): 53x53	Product Depth: 137
Product weight (g): 20	Thickness: 300+260gsm	Use: Hot & Wet Products
Manufactured: Taiwan	Customise: Print	MOQ custom: 100000
Mould fees: Yes - see custom packaging	Environmental production certified: None	Quality product certified: TBC
Factory food safety certified: BRC	Corporate social accreditation: BSCI	Home compostable: Certified to AS5810 Australian standards, Certified to NF T51-800 European standards
Industrially compostable: Certified to AS4736 Australian Standards, Certified to EN13432 European Standard	Recyclable: No	