

## 390ml / 12oz (90mm) Kraft Green Stripe Double Wall BioCup BCK-12DW-GS-V2

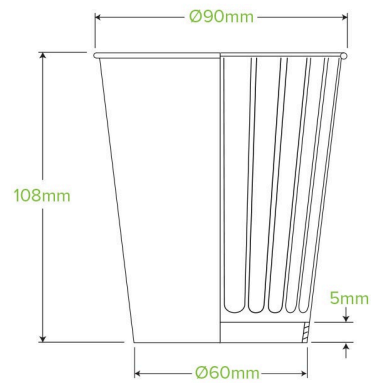

Paper Double Wall BioCups are lined with a water-based aqueous coating and certified home compostable (AS5810). This 12oz Green Stripe BioCup is printed kraft-look. This takeaway cup fits our large lids

<b>Carton quantity:</b> 1000	<b>Sleeves per carton:</b> 25	<b>Units per sleeve:</b> 40
<b>Carton Size LxWxH (cm):</b> 46.5x46.5x59.5	<b>Carton gross weight (kg):</b> 18.600000	<b>Raw material:</b> Paper
<b>Lining/coating:</b> Aqueous	<b>Window material:</b> None	<b>Printing Type:</b> Offset
<b>Inks:</b> Food Contact Safe Inks	<b>Brim fill capacity (ml):</b> 391	<b>Dimensions top LxW (mm):</b> 90x90
<b>Dimensions base LxW (mm):</b> 60x60	<b>Product Depth:</b> 108	<b>Product weight (g):</b> 18
<b>Thickness:</b> 285gsm + 35gsm	<b>Use:</b> Hot and cold	<b>Manufactured:</b> Taiwan
<b>Customise:</b> Print	<b>MOQ custom:</b> 50000	<b>Mould fees:</b> No
<b>Quality product certified:</b> ISO 9001	<b>Factory food safety certified:</b> BRC, HACCP	<b>Home compostable:</b> Certified to AS5810 Australian standards, Certified to NF T51-800 European standards
<b>Industrially compostable:</b> Certified to AS4736 Australian Standards, Certified to EN13432 European Standard	<b>Recyclable:</b> No	