

460ml / 16oz (90mm) Black Double Wall BioCup BC-16DWB

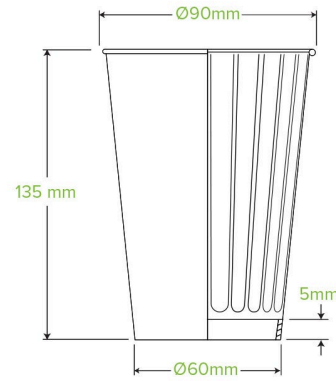

16oz Aqueous Double Wall BioCups are manufactured using a unique water-based dispersion coating certified home compostable to Australian standards (AS5810). These cups are food safe, odorless, and can be disposed of right in your backyard compost bin!

Carton quantity: 600	Sleeves per carton: 15	Units per sleeve: 40
Carton Size LxWxH (cm): 46.5x28.5x63	Carton gross weight (kg): 13.000000	Raw material: Paper
Lining/coating: Aqueous	Window material: None	Printing Type: Offset
Inks: Food Contact Safe Inks	Brim fill capacity (ml): 395	Dimensions top LxW (mm): 90x90
Dimensions base LxW (mm): 53x53	Product Depth: 137	Product weight (g): 20
Thickness: 300+260gsm	Use: Hot & Wet Products	Manufactured: China
Customise: Print	MOQ custom: 100000	Mould fees: Yes - see custom packaging
Environmental production certified: None	Quality product certified: TBC	Factory food safety certified: BRC
Corporate social accreditation: BSCI	Home compostable: Certified to AS5810 Australian standards, Certified to NF T51-800 European standards	Industrially compostable: Certified to AS4736 Australian Standards, Certified to EN13432 European Standard
Recyclable: No		