

Unlined Small Enclosed BioBoard Chip Box BB-CHIP-S

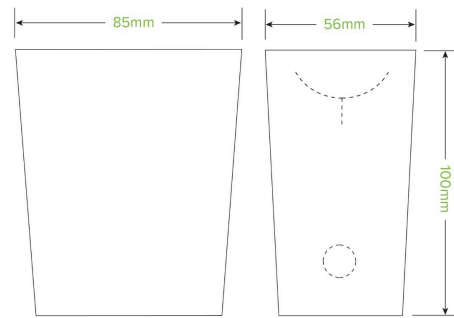

Our Enclosed Chip Boxes are made from premium paperboard and have a self-closing lid that protects chips during transit. This functional, secure design allows for efficient takeaway that avoids any spillage in takeaway bags. The ventilation holes prevent the chips from going soggy. Home compostable and recyclable if clean. Available in small & large.

Carton quantity: 800	Sleeves per carton: 8	Units per sleeve: 100
Carton Size LxWxH (cm): 62.5x15x38	Carton gross weight (kg): 9.800000	Carton barcode: 19344062072338
Raw material: Paper - Recycled Paper Pulp	Lining/coating: None	Window material: None
Printing Type: Offset	Inks: Food Contact Safe Inks	Brim fill capacity (ml): 388
Dimensions top LxW (mm): 85x55	Dimensions base LxW (mm): 70x45	Product Depth: 100
Product weight (g): 10.67	Thickness: 260gsm	Use: Hot and cold
Manufactured: China	Customise: Print	MOQ custom: 30000
Mould fees: No	Environmental production certified: ISO 14001	Quality product certified: ISO 9001
Factory food safety certified: BRC	Corporate social accreditation: BSCI	Home compostable: Suitable for composting
Industrially compostable: Suitable for composting	Recyclable: No	