

950ml Natural Plant Fibre Octa Takeaway Base B-LB-OCTA-950-N

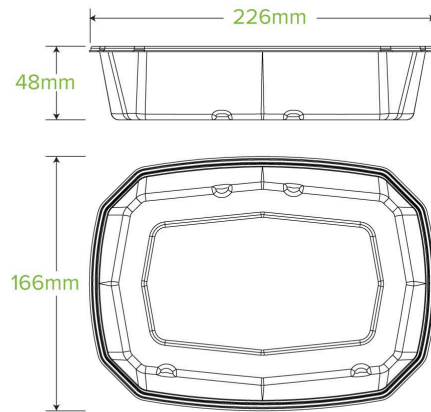

Our 950ml natural Octa takeaways are made from reclaimed and rapidly renewable sugarcane pulp, a by-product made of the sugar refining industry. They have a unique octagonal shape for a premium look and feel.

Carton quantity: 400	Sleeves per carton: 8	Units per sleeve: 50
Carton Size LxWxH (cm): 47x47x35	Carton gross weight (kg): 13.000000	Carton barcode: 19344062053689
Raw material: Plant Fibre With PFAS	Lining/coating: None	Window material: None
Printing Type: None	Inks: None	Brim fill capacity (ml): 1180
Dimensions top LxW (mm): 227	Dimensions base LxW (mm): 168	Product Depth: 52
Product weight (g): 30	Thickness: 0.6mm	Use: Hot, Cold, Wet & Dry Products
Manufactured: China	Customise: Yes - Please Contact Our Team For More Information	MOQ custom: MOQ apply see custom packaging
Mould fees: Yes - see custom packaging	Environmental production certified: ISO 14001	Quality product certified: ISO 9001
Factory food safety certified: BRC	Corporate social accreditation: BSCI	Home compostable: No
Industrially compostable: No	Recyclable: No	