

500ml & 600ml Clear RPET Takeaway Lid B-LBL-RPET(D) SMALL

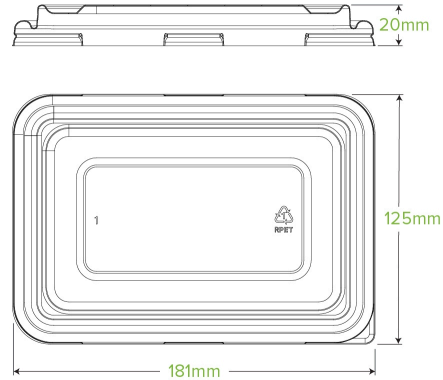

Our rPET clear lids are great for packaging cold food. They are not compatible with hot foods, microwave or oven heating. This is the matching lid for the 500 & 600ml sugarcane takeaway container bases. Recyclable in most councils.

Carton quantity: 500	Sleeves per carton: 10	Units per sleeve: 50
Carton Size LxWxH (cm): 64x35.5x38.3	Carton gross weight (kg): 7.000000	Carton barcode: 19344062033988
Raw material: Plastic - Recycled PET (Polyethylene Terephthalate)	Lining/coating: None	Window material: None
Printing Type: None	Inks: None	Dimensions top LxW (mm): 182x125.4
Dimensions base LxW (mm): 182x125.4	Product Depth: 20.4	Product weight (g): 12.5
Thickness: 0.4	Use: Cold use only	Manufactured: China
Customise: Emboss	MOQ custom: 100000	Mould fees: Yes - see custom packaging
Environmental production certified: ISO 14001	Quality product certified: ISO 9001	Factory food safety certified: FSSC 22000
Corporate social accreditation: BSCI, SMETA	Home compostable: No	Industrially compostable: No
Recyclable: Yes		