

480ml / 16oz BioBoard Noodle Box BB-NB-16

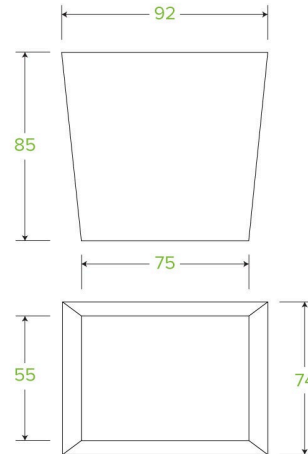

BioBoard Noodle Boxes are made from sustainably sourced FSC™ Mix certified paperboard and lined with waterproof Ingeo™ – a bioplastic product made from plants, not oil. This 16oz box is printed kraft-look. Certified industrially compostable to AS4736.

Carton quantity: 500	Sleeves per carton: 10	Units per sleeve: 50
Carton Size LxWxH (cm): 68.5x24x39	Carton gross weight (kg): 10.400000	Carton barcode: 19344062028045
Raw material: Paper - FSC™ Mix certified paper	Lining/coating: Bioplastic - Ingeo™ PLA	Window material: None
Printing Type: Offset	Inks: Food Contact Safe Inks - Soy or Water Based	Brim fill capacity (ml): 458
Dimensions top LxW (mm): 92x74	Dimensions base LxW (mm): 75x55	Product Depth: 85
Product weight (g): 16	Thickness: 270gsm	Use: Hot and cold
Manufactured: China	Customise: Print	MOQ custom: 30000
Mould fees: No	Environmental production certified: ISO 14001	Quality product certified: NA
Factory food safety certified: BRC, ISO 22000	Corporate social accreditation: NONE AVAILABLE	Home compostable: No
Industrially compostable: Certified to AS4736 Australian Standards, Certified to EN13432 European Standard	Recyclable: No	