

## 1,000ml White BioBoard Takeaway Base BB-LB-1000-W

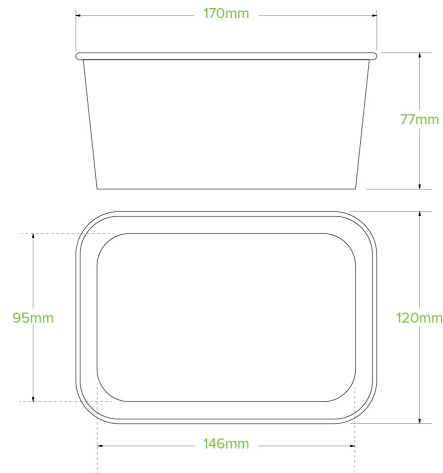

BioBoard Rectangular Paper Containers are sustainably sourced and made from FSC™ certified paper board. These eco-friendly food containers are lined with waterbased, waterproof coating. This food packaging is perfect for hot and greasy food.

<b>Carton Quantity:</b> 300	<b>Sleeves per UOM:</b> 6	<b>Units per sleeve:</b> 50
<b>Carton Size:</b> 38x36x47.5	<b>Gross Weight:</b> 7.100000	<b>Barcode Carton:</b> 19344062067815
<b>Item Raw Material:</b> Paper - FSC™ Mix certified paper	<b>Item Lining:</b> Aqueous	<b>Item Window:</b> None
<b>Ink:</b> Food Contact Safe Inks - Soy or Water Based	<b>Brim full capacity:</b> 1000	<b>Dimensions Top:</b> 173
<b>Dimensions Base:</b> 121	<b>Product Depth:</b> 75	<b>Weight (per unit):</b> 20
<b>Thickness:</b> 320gsm+26g	<b>Item Use:</b> Hot and cold	<b>Manufactured:</b> China
<b>Customise:</b> Print	<b>MOQ Custom:</b> 30000	<b>Mould fees:</b> Yes - see custom packaging
<b>Environmental production certified:</b> ISO 14001	<b>Quality product certified:</b> ISO 9001	<b>Factory food safety certified:</b> BRC
<b>Corporate social accreditation:</b> BSCI	<b>Home compostable:</b> Pending Certification to AS5810 Australian Standards, Pending Certification to NF T51-800 European Standards	<b>Industrially compostable:</b> No
<b>Recyclable:</b> No		