

## 1,000ml Kraft BioBoard Takeaway Base BB-LB-1000-N

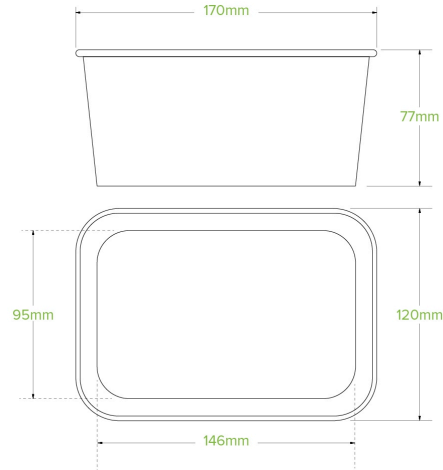

1,000ml Natural Rectangular Paper Containers are sustainably sourced and made from FSC™ certified paper board. They are lined with waterbased, waterproof coating. These takeaway containers are perfect for hot and greasy food.

|                                                            |                                                                                                                                       |                                               |
|------------------------------------------------------------|---------------------------------------------------------------------------------------------------------------------------------------|-----------------------------------------------|
| <b>Carton Quantity:</b> 300                                | <b>Sleeves per UOM:</b> 6                                                                                                             | <b>Units per sleeve:</b> 50                   |
| <b>Carton Size:</b> 38x36x47.5                             | <b>Gross Weight:</b> 7.100000                                                                                                         | <b>Barcode Carton:</b> 19344062067686         |
| <b>Item Raw Material:</b> Paper - FSC™ Mix certified paper | <b>Item Lining:</b> Aqueous                                                                                                           | <b>Item Window:</b> None                      |
| <b>Ink:</b> Food Contact Safe Inks - Soy or Water Based    | <b>Brim full capacity:</b> 1000                                                                                                       | <b>Dimensions Top:</b> 173                    |
| <b>Dimensions Base:</b> 121                                | <b>Product Depth:</b> 75                                                                                                              | <b>Weight (per unit):</b> 20                  |
| <b>Thickness:</b> 320gsm+26g                               | <b>Item Use:</b> Hot and cold                                                                                                         | <b>Manufactured:</b> China                    |
| <b>Customise:</b> Print                                    | <b>MOQ Custom:</b> 30000                                                                                                              | <b>Mould fees:</b> Yes - see custom packaging |
| <b>Environmental production certified:</b> ISO 14001       | <b>Quality product certified:</b> ISO 9001                                                                                            | <b>Factory food safety certified:</b> BRC     |
| <b>Corporate social accreditation:</b> BSCI                | <b>Home compostable:</b> Pending Certification to AS5810 Australian Standards, Pending Certification to NF T51-800 European Standards | <b>Industrially compostable:</b> No           |
| <b>Recyclable:</b> No                                      |                                                                                                                                       |                                               |