

## 460ml / 16oz (90mm) Art Series Double Wall BioCup BC-16DW-ART SERIES

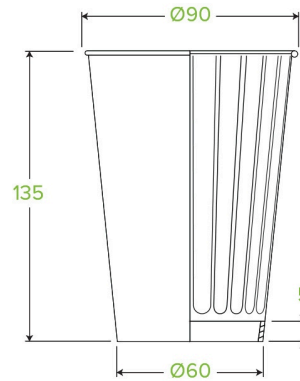

\*image as a guide only



Art Series paper BioCups are manufactured using a Aqueous water dispersion coating. BioPak paper cups are certified home compostable (AS5810). This 16oz double-wall art series fits our large lids.

<b>Carton Quantity:</b> 600	<b>Sleeves per UOM:</b> 15	<b>Units per sleeve:</b> 40
<b>Carton Size:</b> 46.5x28.5x63	<b>Gross Weight:</b> 13.000000	<b>Barcode Carton:</b> 19344062011504
<b>Item Raw Material:</b> Paper	<b>Item Lining:</b> Aqueous	<b>Item Window:</b> None
<b>Item Printing Type:</b> Offset	<b>Ink:</b> Food Contact Safe Inks	<b>Brim full capacity:</b> 395
<b>Dimensions Top:</b> 90x90	<b>Dimensions Base:</b> 53x53	<b>Product Depth:</b> 137
<b>Weight (per unit):</b> 20	<b>Thickness:</b> 300+260gsm	<b>Item Use:</b> Hot & Wet Products
<b>Manufactured:</b> Taiwan	<b>Customise:</b> Print	<b>MOQ Custom:</b> 100000
<b>Mould fees:</b> Yes - see custom packaging	<b>Quality product certified:</b> ISO 9001	<b>Factory food safety certified:</b> BRC,HACCP
<b>Corporate social accreditation:</b> BSCI	<b>Home compostable:</b> Certified to AS5810 Australian standards,Certified to NF T51-800 European standards	<b>Industrially compostable:</b> Certified to AS4736 Australian Standards,Certified to EN13432 European Standards
<b>Recyclable:</b> No		