

## 295ml / 8oz (90mm) White Double Wall BioCup BC-8DWW(90)

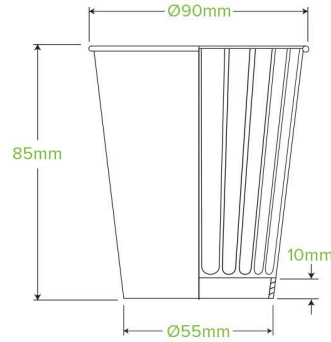

White paper BioCups are manufactured using a Aqueous water dispersion coating. BioPak paper cups are certified home compostable (AS5810). This 8oz (90mm) white double-wall cup fits our large lids.

<b>Carton Quantity:</b> 1000	<b>Sleeves per UOM:</b> 20	<b>Units per sleeve:</b> 50
<b>Carton Size:</b> 46.5x37.5x60.5	<b>Gross Weight:</b> 12.840000	<b>Barcode Carton:</b> 19344062014109
<b>Item Raw Material:</b> Paper	<b>Item Lining:</b> Aqueous	<b>Item Window:</b> None
<b>Item Printing Type:</b> Offset	<b>Ink:</b> Food Contact Safe Inks	<b>Brim full capacity:</b> 296
<b>Dimensions Top:</b> 90x90	<b>Dimensions Base:</b> 54x54	<b>Product Depth:</b> 86
<b>Weight (per unit):</b> 12.6	<b>Thickness:</b> 280+260gsm	<b>Item Use:</b> Hot & Wet Products
<b>Manufactured:</b> Taiwan	<b>Customise:</b> Print	<b>MOQ Custom:</b> 100000
<b>Mould fees:</b> Yes - see custom packaging	<b>Quality product certified:</b> ISO 9001	<b>Factory food safety certified:</b> BRC, HACCP
<b>Corporate social accreditation:</b> BSCI	<b>Home compostable:</b> Certified to AS5810 Australian standards, Certified to NF T51-800 European standards	<b>Industrially compostable:</b> Certified to AS4736 Australian Standards, Certified to EN13432 European Standards
<b>Recyclable:</b> No		