

510ml / 16oz (90mm) Indigenous Art Single Wall BioCup BC-16-CCAB

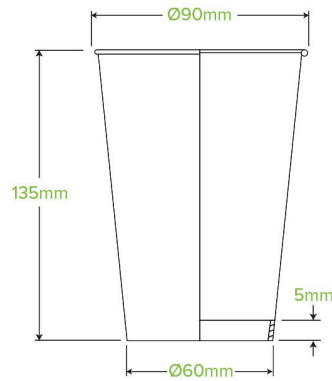

A cup with a cause. Purchasing the 16oz Indigenous single wall cups directly supports CorporateConnect.AB's pro-bono work assisting Indigenous youth. Paper BioCups are lined with a plant-based bioplastic. This cup is printed kraft-look. This 12oz double wall cup fits our large lids.

Carton quantity: 1000	Sleeves per carton: 20	Units per sleeve: 50
Carton Size LxWxH (cm): 46x37x56	Carton gross weight (kg): 13.150000	Raw Material: Paper
Lining/coating: Aqueous	Window Material: None	Inks: Food Contact Safe Inks
Brim fill capacity (ml): 520	Product Depth: 136	Product weight (g): 12.3
Thickness: 300gsm	Use: Hot & Wet Products	Manufactured: China
Customise: Print	MOQ custom: 100000	Mould fees: Yes
Environmental production certified: ISO 14001	Quality product certified: ISO 9001	Factory food safety certified: BRC, HACCP
Corporate social accreditation: BSCI	Home compostable: Yes	Industrially compostable: Certified to AS4736 Australian Standards, Certified to EN13432 European Standard
Recyclable: Yes		