

## 460ml / 16oz (90mm) Indigenous Art Double Wall BioCup BC-16DW-CCAB

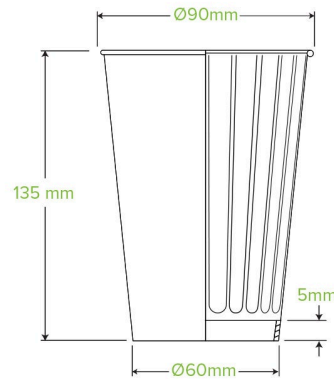

Indigenous Art series Double Wall BioCup manufactured using a Aqueous water dispersion coating. BioPak paper cups are certified home compostable (AS5810), and Certified Industrially Compostable (AS4736). This 16oz Indigenous Double Wall BioCup fits our 90mm Lids.

<b>Carton quantity:</b> 600	<b>Sleeves per carton:</b> 15	<b>Units per sleeve:</b> 40
<b>Carton Size LxWxH (cm):</b> 45.5x28x61	<b>Carton gross weight (kg):</b> 12.850000	<b>Raw Material:</b> Paper
<b>Lining/coating:</b> Aqueous	<b>Window Material:</b> None	<b>Inks:</b> Food Contact Safe Inks
<b>Brim fill capacity (ml):</b> 395	<b>Product Depth:</b> 137	<b>Product weight (g):</b> 20
<b>Thickness:</b> 300+260gsm	<b>Use:</b> Hot & Wet Products	<b>Manufactured:</b> China
<b>Customise:</b> Print	<b>MOQ custom:</b> 100000	<b>Mould fees:</b> Yes
<b>Environmental production certified:</b> ISO 14001	<b>Quality product certified:</b> ISO 9001	<b>Factory food safety certified:</b> BRC, HACCP
<b>Corporate social accreditation:</b> BSCI	<b>Home compostable:</b> Yes	<b>Industrially compostable:</b> Yes
<b>Recyclable:</b> Yes		