

## 750ml Kraft BioBoard Takeaway Base BB-LB-750-N

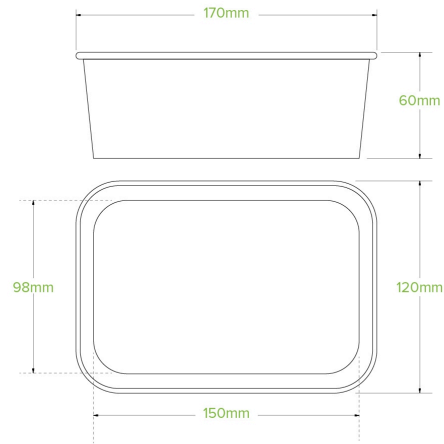

These 750ml Natural BioBoard Rectangular Paper Containers are sustainably sourced and made from FSC™ certified paper board. They are lined with a waterbased, waterproof coating. These takeaway containers are perfect for hot and greasy food.

<b>Carton quantity:</b> 300	<b>Sleeves per carton:</b> 6	<b>Units per sleeve:</b> 50
<b>Carton Size LxWxH (cm):</b> 38x36x46	<b>Carton gross weight (kg):</b> 6.200000	<b>Carton barcode:</b> 19344062067679
<b>Raw Material:</b> Paper - FSC™ Mix certified paper	<b>Lining/coating:</b> Aqueous	<b>Window Material:</b> None
<b>Printing Type:</b> Flexo	<b>Inks:</b> Food Contact Safe Inks - Soy or Water Based	<b>Brim fill capacity (ml):</b> 750
<b>Dimensions top LxW (mm):</b> 173	<b>Dimensions base LxW (mm):</b> 121	<b>Product Depth:</b> 57
<b>Product weight (g):</b> 17	<b>Thickness:</b> 320gsm+26g	<b>Use:</b> Hot and cold
<b>Manufactured:</b> China	<b>Customise:</b> Print	<b>MOQ custom:</b> 30000
<b>Mould fees:</b> Yes - see custom packaging	<b>Environmental production certified:</b> ISO 14001	<b>Quality product certified:</b> ISO 9001
<b>Factory food safety certified:</b> BRC	<b>Corporate social accreditation:</b> BSCI	<b>Home compostable:</b> Pending Certification to AS5810 Australian Standards, Pending Certification to NF T51-800 European Standards
<b>Industrially compostable:</b> No	<b>Recyclable:</b> No	