

BioBoard Wrap Wedge BB-WRAP

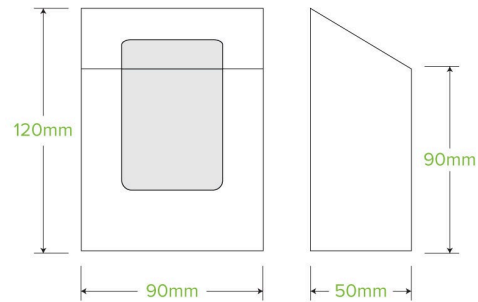

BioBoard Wrap Wedges are made from sustainably sourced FSC™ Mix certified paperboard with a waterproof Ingeo™ bioplastic window. This tortilla wrap box is printed kraft-look. Certified industrially compostable to AS4736.

Carton quantity: 600	Sleeves per carton: 6	Units per sleeve: 100
Carton Size LxWxH (cm): 45x20x29.5	Carton gross weight (kg): 7.700000	Carton barcode: 19344062046018
Raw Material: Paper - FSC™ Mix certified paper	Lining/coating: None	Window Material: Bioplastic - PLA
Printing Type: Offset	Inks: Food Contact Safe Inks - Soy or Water Based	Brim fill capacity (ml): 470
Dimensions top LxW (mm): 90x50	Dimensions base LxW (mm): 90x50	Product Depth: 120
Product weight (g): 11.9	Thickness: 270gsm	Use: Hot and cold
Manufactured: China	Customise: Print	MOQ custom: 30000
Mould fees: No	Environmental production certified: ISO 14001	Quality product certified: NA
Factory food safety certified: BRC, ISO 22000	Corporate social accreditation: NONE AVAILABLE	Home compostable: No
Industrially compostable: Certified to AS4736 Australian Standards, Certified to EN13432 European Standard	Recyclable: No	