

390ml / 12oz (90mm) Art Series Single Wall BioCup BC-12-ART SERIES

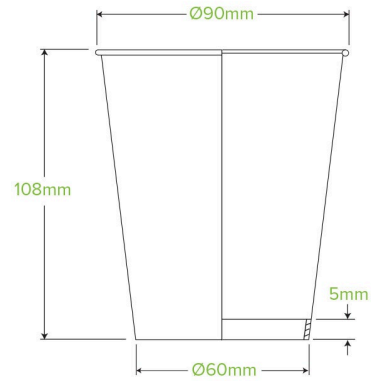

*image as a guide only



Art Series paper BioCups are manufactured using an Ingeo™ coating. BioPak paper cups are certified industrially compostable (AS4736). This 12oz art series fits our large lids.

Carton quantity: 1000	Sleeves per carton: 20	Units per sleeve: 50
Carton Size LxWxH (cm): 46.7x36.8x53	Carton gross weight (kg): 12.700000	Carton barcode: 19344062009075
Raw Material: Paper	Lining/coating: Aqueous	Window Material: None
Printing Type: Offset	Inks: Food Contact Safe Inks	Brim fill capacity (ml): 410
Dimensions top LxW (mm): 90x90	Dimensions base LxW (mm): 60x60	Product Depth: 108
Product weight (g): 10.1	Thickness: 300gsm	Use: Hot & Wet Products
Manufactured: Taiwan	Customise: Print	MOQ custom: 100000
Mould fees: Yes - see custom packaging	Environmental production certified: None	Quality product certified: TBC
Factory food safety certified: BRC	Corporate social accreditation: BSCI	Home compostable: Certified to AS5810 Australian standards, Certified to NF T51-800 European standards
Industrially compostable: Certified to AS4736 Australian Standards, Certified to EN13432 European Standard	Recyclable: No	